



**Positherm<sup>®</sup>**  
**Positherm<sup>®</sup> Non-Splash**  
Fast, accurate, and reliable liquid metal  
temperature readings

# Positherm<sup>®</sup> and Positherm<sup>®</sup> Non-Splash

## Fast, accurate, and reliable liquid metal temperature readings

The knowledge of liquid metal temperature is essential for the production and quality control of steel, cast iron and non-ferrous alloys. The molten metal temperature must be within strict limits to achieve the optimum quality before the heat or melt can be tapped or cast.

High performance expendable temperature sensors from Heraeus Electro-Nite offer a wide choice of thermocouple types, probe lengths, and immersion lances to suit all process applications.

### Positherm<sup>®</sup> disposable immersion thermocouple

Fast, accurate, and reliable liquid metal temperature readings are indispensable tools for cost-effective temperature control during steel production.

Supplied as ready-made units, Positherm<sup>®</sup> expendable thermocouples are easy to use and require no special skill from the operator.



### Positherm<sup>®</sup> Non-Splash

For applications where the operator stands near to the liquid metal, such as small furnaces, ladles, runners, tundishes and moulds, it is recommended to use the Positherm<sup>®</sup> Non-Splash thermocouple.

The splash-free material was selected based on its non-splash characteristics and ecological properties. Major components are AES fibers, binder and filler.



Under favourable conditions, Positherm<sup>®</sup> Non-Splash thermocouples may even be used for multiple immersion although they are not designed for this.

Positherm<sup>®</sup> Non-Splash thermocouples are available in various standard non-splash lengths and cardboard tubes.

### Positherm<sup>®</sup> for close-up measurements

For repeated measurements in small, slag free melts where only the quartz tube is immersed, Heraeus Electro-Nite designed its Positherm<sup>®</sup> for close-up applications. It consists of a PtRh/Pt-thermocouple in an extra long quartz protection tube, cemented in a ceramic housing, and fitted with a special high temperature connector assuring complete contact even after a number of dips. Depending on the intervals between successive immersions and the metal temperature, the number of measurements may vary. The use of a small cardboard tube for thermal protection of contact block and probe holder is recommended.



## Features

### Application field

Molten metal temperature measurement in the blast furnace runner, torpedo car, converter, electric furnace, ladle, tundish, mould, foundry, copper melts and different alloys.

### Calibration

Positherm<sup>®</sup> thermocouples are available in following calibrations according to IEC 584-1 based on the ITS 90 temperature scale:

PT 10% Rh / Pt (type S), temperature range: -50 to 1767°C

PT 13% Rh / Pt (type R), temperature range: -50 to 1767°C

PT 30% Rh / Pt 6% Rh (type B), temperature range: -50 to 1820°C

The thermocouple wires are rigorously selected in order to guarantee an accuracy of +/- 1.5°C at 1553.5°C (Pd melting point).

### Cardboard tube lengths

To suit different applications, Positherm<sup>®</sup> thermocouples are available in several nominal lengths ranging from 150 to 1700mm. For application in big vessels, the use of telescopic oversleeves is recommended to provide an additional thermal protection of the immersion lance.

### Metal caps

A metal cap protects the thermocouple assembly during transport and immersion through the slag. It is made of steel for application in steel melts. For application in low temperature steel, cast iron and aluminium alloys, an aluminium protection cap is used. A copper cap is used for measurements in copper alloys.

### Common features

- Measuring time 3 to 6 s
- Maximum immersion time: 7s at 1650°C
- Diameter of protective cardboard tube:
  - inner: 17.9 mm
  - outer: 29.5 mm

## Description of a typical measurement system

The Positherm<sup>®</sup> thermocouple is pushed upon the probe holder of a suitable immersion lance until electrical contact is achieved with a built in contact block. An inner and outer extension cable related to the thermocouple type connects the immersion lance to the measuring instrument (e.g. Digitemp-E and Digilance V). Next, the thermocouple is dipped into the molten metal until the end of measurement signal is given by the instrumentation.

### Immersion Lances

Positherm<sup>®</sup> thermocouples may be dipped either by means of an appropriate hand lance (Fig. 1) or an automatic lance. For quick and easy change of the lower part of automated lances including contact block and probe holder, Heraeus Electro-Nite developed the Quick Connecting Lance system (Fig. 2).

A large range of ready-made manual immersion lances, straight or bent, can be supplied to suit customer's needs. Components may be ordered separately.

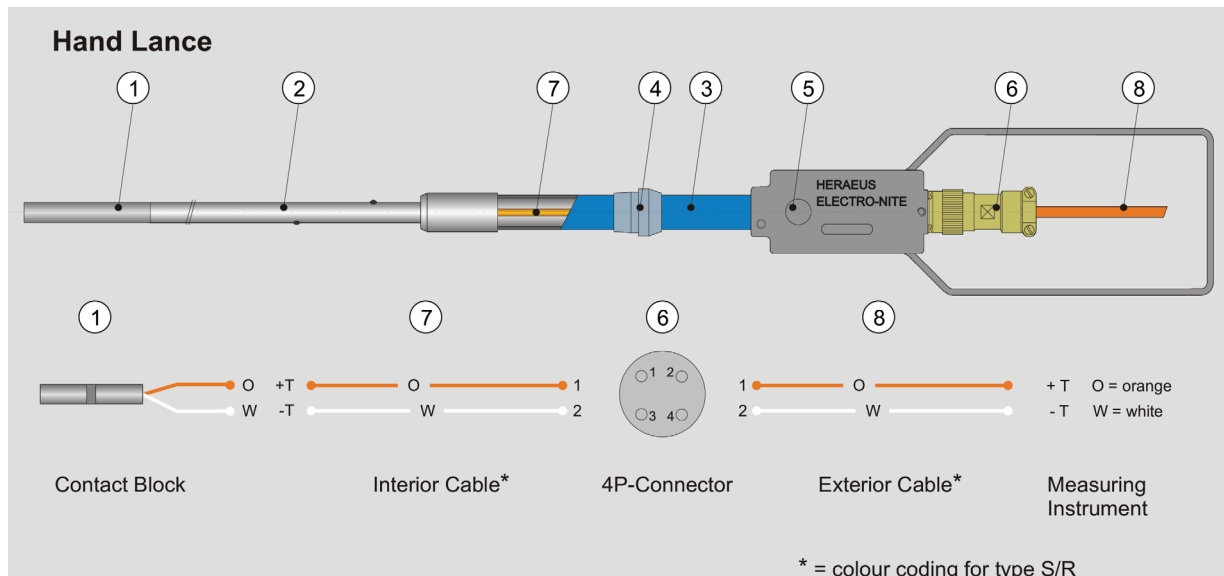

Fig. 1

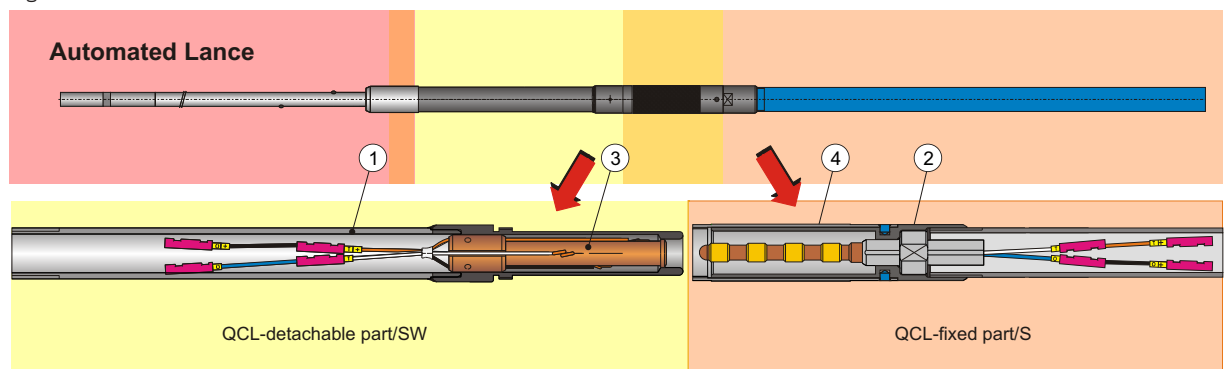

Fig. 2

### Measuring instrument

There are two distinct systems based on handheld or wall mounted instruments. Both systems have the optional capability to wirelessly transmit measurement results. The advantage of handheld systems is that they stand alone. Wall mounted instruments need additional hardware.



#### Digilance V

Digilance V is the latest most advanced handheld temperature instrument for molten metal applications available today.

- Using platinum-based immersion thermocouples, the instrument can measure temperatures up to 1820°C (3308°F) in all ferrous and non-ferrous applications.
- Ready (green), Measure (yellow), and Complete (red) LEDs signal the measurement status, with a buzzer on completion.
- The temperature result is locked on the display after a typical measurement time of 5-8 seconds and the last 500 measurements are internally stored.
- Standard configuration ensures that the instrument is plug and play.
- Available as a Standard Measure-and-Display model and a Wireless model, which incorporates real-time wireless data transfer.



#### DigiTemp®-E

DigiTemp®-E is a wall mounted instrument. The hand lance is connected to the instrument by means of an external compensation cable or wireless without cable (QUBE®), a heavier construction

Located near the handle of the optional QUBE measurement lance is the QUBE T battery-powered wireless transmission module, which transfers the temperature measurement data directly to the DigiTemp-E Wireless instrument.

##### Safety-related benefits

- no accident risks through cables lying around
- no repairs in security restricted and hazardous environments

##### Cost-relevant advantages

- no wiring or cable connection between the submersible measuring probe and measuring instrument, cost savings for repairing of damaged cables
- no attachment of cable conduit/terminal blocks

**Heraeus Electro-Nite**  
info.electro-nite.be@heraeus.com  
www.heraeus-electro-nite.com

